

WNMG / Turning

Negative insert / triangle 80°

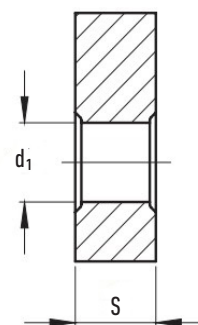
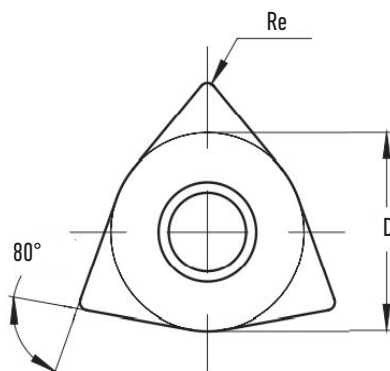
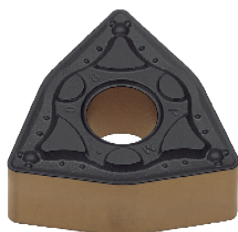

Code	Dimensions					Cutting conditions					
	D	S	Re	d ₁	A _p	A _{pmin.}	A _{pmax.}	F _z	F _{zmin.}	F _{zmax.}	
	(mm)					Chip depth (mm)			Feed (mm/t)		
WNMG080404M	● ○	12,700	4,76	0,40	5,16	2,50	0,50	4,00	0,22	0,10	0,30
WNMG080408M	● ○	12,700	4,76	0,80	5,16	2,50	0,50	4,00	0,30	0,15	0,50
WNMG080412M	● ○	12,700	4,76	1,20	5,16	2,50	0,80	4,00	0,35	0,18	0,60